

SPECIFICATIONS - TRACKING SYSTEM WITH TYPE 2R DIGITAL HEAD

Remote Head

Camera	Any tri-ax camera, Panasonic AWE800
Lens	Canon, Sony, Fujinon
Remote Head	Camera Corps ' Type IIR ' head
Lens height from floor or support	Minimum 380mm

Track Sizes

Track gauge	300mm
Track length (2m sections)	Up to 60m
Width for safe clearance of track	650mm
Width for safe clearance of camera and head	750mm
Height for clearance	600mm

Track Speeds

Max Speed - 3 phase power	6m/sec
Max Acceleration - 3 phase power	4.5m/sec*sec
Max Speed - Single phase power	3.5m/sec
Max Acceleration - Single phase power	3m/sec*sec

Track Control

Motion control	Fully programmed End stops/Accel/Decel/Safety cut-outs
Operator inputs	Proportional Joystick/Proportional Foot pedals/Button Console/Directional Footswitches

Special Requirements

Operating Position	In operators line of sight
--------------------	----------------------------

Track Power & Cabling

Power Supply	32 amp, 3 phase or 13 -16 amp, single phase
Maximum distance to operating position for cables	100m

Shipping Weights & Sizes - (20 metre System)

	Sizes in mm : Length x Width x Height - Weight in kg
Gross Weight	920kg
Motor Units - wheeled flight case	L =1000 x W=550 x H=1200 - 65kg
Track - 10 sections (1 wheeled pallet)	L =2000 x W=760 x H=1350 - 475kg
Dolly/Single Phase Drive/Cables/Control Console/Operators Kit/Spares - wheeled flight case	L =1400 x W=650 x H=1100 - 250kg
Type 2R Digital Head	L =1000 x W=250 x H=600 - 35kg

Shipping Weights & Sizes - (50 metre System)

	Sizes in mm : Length x Width x Height - Weight in kg
Gross Weight	1867kg
Motor Units - wheeled flight case	L =1000 x W=550 x H=1200 - 65kg
Track - 26 sections (3 wheeled pallets)	L =2000 x W=760 x H=1350 - 475kg
Dolly/Single Phase Drive/Cables/Control Console/Operators Kit/Spares - wheeled flight case	L =1400 x W=650 x H=1100 - 250kg
Type 2R Digital Head	L =1000 x W=250 x H=600 - 35kg

This information is for guidance only and may differ subject to requirements

300mm GAUGE TRACK WITH TYPE 2 HEAD AND STANDARD DOLLY

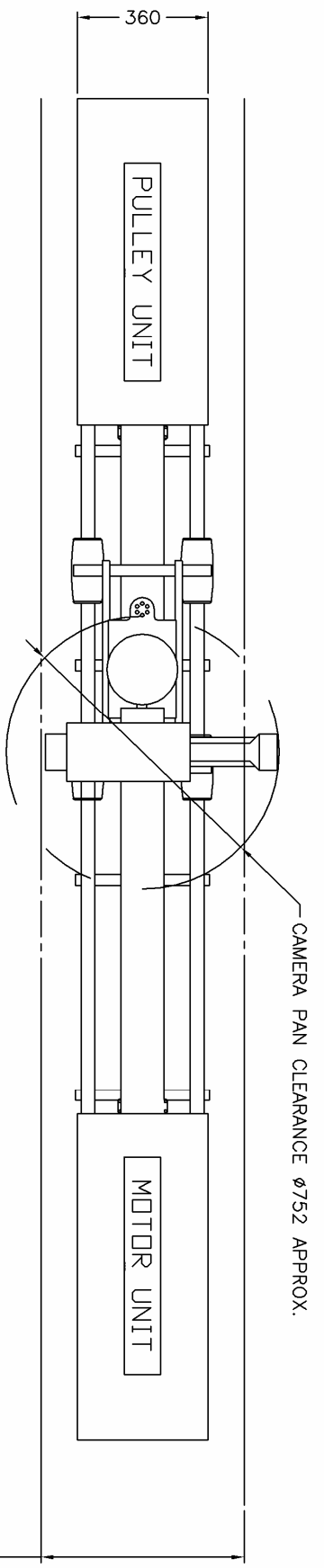
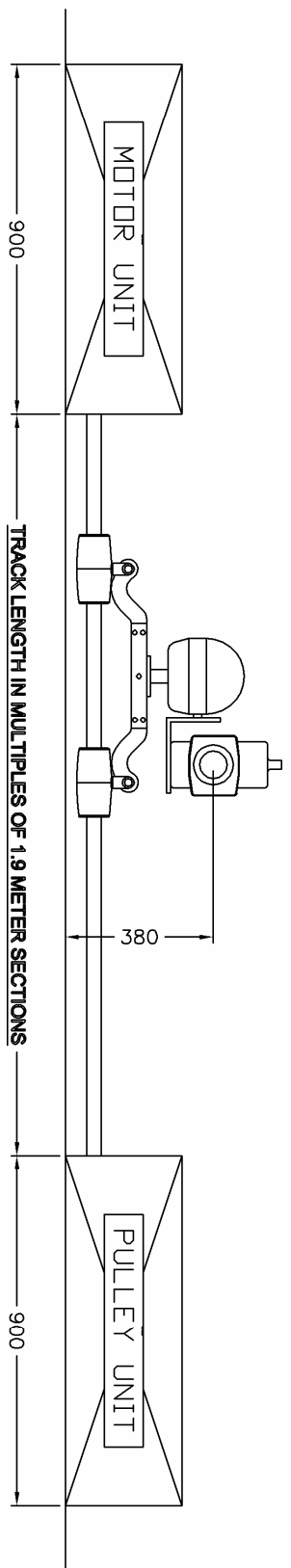

CLEARANCE AT GROUND LEVEL 560