

Preliminary**HDTV digital color camera**

DK-H32



The new DK-H32 HDTV special application camera is ideal for graphics stand, point of view and remote observation applications. Images of the highest quality and stability are assured with the three 2/3" 2.2-million pixels CCDs and a 1.8 million-gate single chip DSP. This high-tech DSP, employs 30-bit accuracy, and was designed for Hitachi's broadcast camera line to outperform traditional analog signal processing. The DK-H32's functions can easily be controlled remotely from a personal computer or dedicated control panel. Command and communications protocol are available to users wishing to build custom software control applications.

Features

- **High S/N with HD-SDI**
Outstanding Signal-to-noise ratio >54dB measured on the HD-SDI (1080i) output.
- **12-bit ADC with the latest generation Hitachi DSP**
High dynamic range and color fidelity are achieved by employing 12-bit analog-to-digital converters on the RGB CCDs' outputs. Hitachi is leading developer for High performance CPU & DSP in Broadcast Fields. Hitachi's highest 0.18μm VLSIC processor with 3 million gates. 30-bit internal processing to provides high dynamic range with superb video stability, Maintenance Free
- **High Resolution**
The three 2/3-inch 2.2million pixel CCDs with microlenses and digital signal processing deliver >1000 TV lines horizontal resolution (Y channel).
- **Small & light weight head**
- **Image enhancements from digital processing**
 - Dyna chroma and auto-knee
 - Flesh tone detail etc.
 - Variable detail boost frequency
 - 6 vector independently variable masking and linear matrix masking
- **Versatile CCD drive functions**
 - Five preset electronic shutter speeds
 - Lock scan mode allows flicker-free pickup of a screen display having a different scanning frequency than the Camera.
 - Automatic electronic shutter (AES) mode sets the video signal to a fixed level.
 - Charge control (CC) frame mode improves vertical resolution.
- **Improved operational ease**
 - Real-time auto white balance detects and automatically compensates for changes in the scene color temperature.
 - A variable white gate permits selection of the area from which real-time auto white balance samples the image. Any light source outside the sampled area will have no effect on the setting of balance.
 - Intelligent automatic level control (ALC)
Digital light metering utilizes a scene into 7 divided sensing areas and an iris gate area with variable size and position.
 - 2 mode gain control
AGC and 3-position programmable high gain switch.
- **Bi-directional data transfer**
An RS-232C input is provided on the camera head to allow remote control from a personal computer.
An ID number for each camera can be registered allowing multiple cameras to be controlled from a single computer.
- **Auxiliary connector for external control**
A simple control box can be connected to the AUX connector for externally controlling the lens zoom/focus and motorized pan/tilt head from a personal computer.
- **Three applications files (standard, observe, microscope).**
Pre-programmed files also allow the user to adjust Detail, Masking, knee, and other functions.
- **Remote filter wheel**
The optical filter wheel can be controlled with RS232C command protocol.
- **Detached Optics Camera**
The DK-H32-S10 HDTV camera with a detached optical block from the camera body is available as a separate but, related product.
The distance between the camera body and the optical block can be extend to 5 meters.
The DK-H32-S10 is specially designed to be used in helicopter and various other applications using gyro-stabilized gimbal camera mounts.

Specifications

CCD	2/3" 2.2 M pixels IT-CCD
Effective pixels	1920(H) x 1080(V)
Aspect ratio	16:9
Scan format	HDTV 1080/59.94i
Horizontal resolution	1000TV lines Y out
Standard sensitivity	2000 lx / F11
Minimum illumination	0.03 lx (F1.4, +18dB, Integration mode)
S/N	54 dB HD-SDI, Y: 30 MHz
Filter wheel	3200K, 5600K, 5600K +1/16ND, 5600K +1/64ND
Shutter	PRESET 1/100, 1/250, 1/500, 1/1000, 1/2000(S)
Lock Scan	1/60.16 to 1/1985 s
AES	OFF to 1/1000 s
Power supply voltage	12 V DC
Power consumption	approx. 22 W
Dimensions (W x H x D)	99 mm x 105 mm x 155 mm
Mass	approx. 1.5 kg
Ambient temperature (operating)	0 to +40 °C
(storage)	-20 to +60 °C

Input signals

Genlock (BNC connector)	Tri-level sync 0.6 Vp-p ±6dB, 75Ω
-------------------------	-----------------------------------

Output signals

HD-SDI 2 output (BNC connector)	0.8 Vp-p, 75Ω
Video output (monitor connector) (selection by menu)	Y or G 1.0 Vp-p (with sync), 75Ω Pb or B 0.7 Vp-p, 75Ω Pr or R 0.7 Vp-p, 75Ω Tri-level sync 0.6 Vp-p, 75Ω

Serial data input/output (4-pin connector) (internal switch)

1.5 Vp-p ±6 dB, high (RU-3300N), RS-232C (for Personal Computer)

Standard composition

Camera head DK-H32	1
Lens Mount Cap	1
Operation Manual	1

Options

Camera control panel	RU-3300N
AC adaptor	IA-60a (I.D.X)

Dimensions

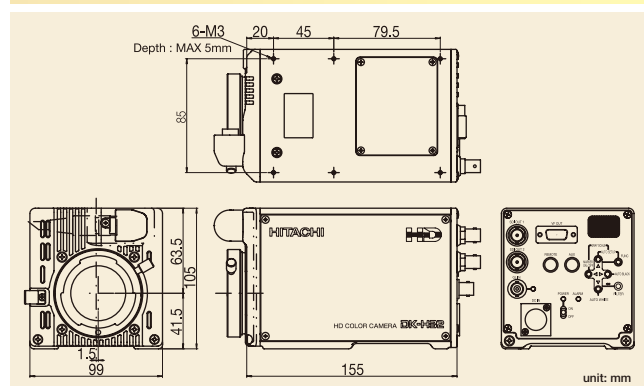

CAUTION: To ensure safe operation, please read the instruction manual before using this product.

Hitachi Kokusai Electric Inc.

Head Office : 14-1, Sotokanda 4-choume, Chiyoda-ku, Tokyo 101-8980, Japan
Phone : +81(0) 3-6734-9432, Fax : +81(0) 3-5209-5942
URL : <http://www.h-kokusai.com>

Hitachi Kokusai Electric (Shanghai) Co., Ltd. Beijing Branch
Room 1413, Beijing Fortune Building, 5 Dong San Huan Bei-Lu, Chao Yang District, Beijing
Phone : +86(0) 10-6590-8755/8756, Fax : +86(0) 10-6590-8757

Hitachi Kokusai Electric America, Ltd. URL : <http://hitachikokusai.us>
Headquarters and Northeast Office : 150 Crossways Park Drive, Woodbury, New York 11797, U. S. A.
Phone : (+1) 516-921-7200, Fax : (+1) 516-496-3718
West Office : 371 Van Ness Way, Suite 120 Torrance, CA. 90501, U. S. A.
Phone : (+1) 310-328-6116, Fax : (+1) 310-328-6252

Midwest Sales : Phone : (+1) 330-334-4115, Fax : (+1) 516-496-3718
Service (+1) 989-345-5379

South Sales : Service (+1) 256-774-3777
Parts Center : Phone : (+1) 516-682-4435, Fax : (+1) 516-921-0993
Latin Sales : Phone : (+1) 516-682-4420, Fax : (+1) 516-496-3718

Hitachi Kokusai Electric Canada, Ltd. URL : www.hitachikokusai.ca

Head Office : 1 Select Avenue Unit#11 Scarborough, Ontario M1V 5J3, Canada
Phone : (+1) 416-299-5900, Fax : (+1) 416-299-0450
Eastern Office : 5795 Chemin St. Francois St. Laurent, Quebec H4S 1B6, Canada
Phone : (+1) 514-332-6687, Fax : (+1) 514-335-1664

Hitachi Kokusai Electric Europe GmbH

Head Office : Weiskircher Straße 88, Jügesheim D-63110 Rodgau, Germany
Phone : +49(0) 6106-69920, Fax : +49(0) 6106-16906
URL : www.hitachi-ke-eu.com
General email address : info@hitachi-ke-eu.com

Hitachi Kokusai Electric U.K. Ltd.

Head Office : Windsor House, Britannia Road, Waltham Cross, Hertfordshire EN8 7NX, United Kingdom
Phone : +44(0) 845-121-2177, Fax : +44(0) 845-121-2180
General email address : info@hitachi-ke-eu.com



CERTIFICATE No.
JMI-0062
ISO 9001/BS 5750P11
EN 29001/JIS Z9901